

SCIENCE FACULTY

NORTH MAHARASHTRA UNIVERSITY, JALGAON

QUESTION BANK

FOR

S. Y. B. Sc. ELECTRONICS

(With effect from June, 2008)

Board of Studies in Electronics

Board of Studies in Electronics, in its meeting held on 13th Aug. 2008, has unanimously appointed the subcommittee for the preparation of question bank. Following members were present.

1. Prof. Dr. D.S. Bhavasar (Chairman)
2. Prof. R.B. Chaudhari
3. Prof. Dr. A.L. Chaudhari
4. Prof. Dr. P.H.Pawar
5. Prof. K.D.Girase
6. Prof. D.B. Patil
7. Prin. R.V. Joshi
8. Prof. Dr. D.S. Patil (Invitee)

Subcommittee appointed for the preparation of question bank

1. Prof. Dr. D.S. Bhavasar - Pratap College Amalner.
2. Prof. K.D.Girase - S.V.S's Arts & Science College, Dondaicha.
3. Prof. S.G. Bachhav - R.C. Patel Arts, Com. & Science College, Shirpur.

PAPEER – I

SEMESTER – I

**ELE – 211: ANALOG CIRCUITS AND
APPLICATIONS.**

SEMESTER – II

**ELE – 222: LINEAR INTEGRATED CIRCUITS
AND APPLICATIONS.**

ELE – 211: ANALOG CIRCUITS AND APPLICATIONS.

1. MULTISTAGE TRANSISTOR AMPLIFIERS

Questions for 2 marks.

1. The absolute gain of an amplifier is 30; find its decibel in gain.
2. The absolute gain of an amplifier is 40; find its decibel in gain.
3. The input power to an amplifier is 10 mw while output power is 1.5 W. Find the gain of the amplifier.
4. The input power to an amplifier is 20 mw while output power is 2.5 W. Find the gain of the amplifier.
5. A multistage amplifier employs 4 stages each of which has a power gain of 20. What is the total gain of the amplifier in db?
6. A multistage amplifier employs 3 stages each of which has a power gain of 30. What is the total gain of the amplifier in db?
7. The gain of the second amplifier in case of two-stage amplifier is low. Comment.
8. What do you understand by multistage transistor amplifier?
9. What is need to of multistage transistor amplifier?
10. Explain the term frequency response with respect to two-stage transformer-coupled amplifier.
11. What are the advantages of frequency with respect to two-stage amplifier?
12. What are the disadvantages of frequency with respect to two-stage transformer-coupled amplifier?
13. Explain the term gain.
14. What is the application of two stage RC coupled amplifier?
15. Draw the block diagram of multistage amplifier.
16. Why do we prefer to express the gain in db?

Questions for 3 marks.

1. We are to match a 16Ω speaker load to an amplifier so that the effective load resistance is $10 K\Omega$. What should be the transformer turn ratio?
2. We are to match a 24Ω speaker load to an amplifier so that the effective load resistance is $12 K\Omega$. What should be the transformer turn ratio?
3. A single stage amplifier has collector load $R_c=10K\Omega$, input resistance $R_{in}=1K\Omega$ and $\beta=100$. If $R_L=100\Omega$ find the voltage gain.

4. A single stage amplifier has collector load $R_c=20K\Omega$, input resistance $R_{in}=2K\Omega$ and $\beta=100$. If $R_L=75\Omega$ find the voltage gain.
5. A multistage amplifier consists of three stages; the voltage gain of the stages are 60,100 and 160 calculate the overall gain.
6. With the neat diagram explain the application of two-stage transformer-coupled amplifier
7. Explain the term frequency response.
8. Explain the term decibel gain.
9. Explain the term bandwidth.
10. Why does transformer coupling give poor frequency response?

Questions for 4 marks.

1. A multistage amplifier consists of four stages; the voltage gain of the stages are 60,80, 100 and 160 calculate the overall gain.
 2. Explain the terms of amplifier I) frequency response and II) decibel gain.
 3. Explain the terms of amplifier I) frequency response and II) bandwidth.
 4. Explain the terms of amplifier I) decibel gain and II) bandwidth.
 5. Explain the frequency response of two-stage RC coupled amplifier.
-
5. A multistage amplifier consists of three stages; the voltage gain of the stages are 60,100 and 160 calculate the overall gain.
 6. How will you achieve impedance matching with transformer coupling?
 7. What are the merits of two-stage transformer coupled amplifier over RC coupled amplifier?
 8. Draw the neat-labeled diagram of two-stage RC coupled amplifier and two-stage transformer coupled amplifier.

Questions for 6 marks.

1. With the neat diagram explain the working of two-stage RC coupled amplifier
2. Explain the terms of amplifier I) frequency response II) decibel gain and III) bandwidth.
3. Explain RC coupled transistor amplifier with special reference to frequency response, advantages, disadvantages and application.
4. With neat diagram explain the working of transformer coupled transistor amplifier.

2. TRANSISTOR AUDIO POWER AMPLIFIERS

Questions for 2 Marks

1. Draw the block diagram practical power amplifier.
2. What is the function of power amplifier?
3. What is the need of power amplifier?
4. Explain voltage amplification stage in case of power amplifier.
5. Explain voltage driver stage in case of power amplifier.
6. Explain voltage output stage in case of power amplifier.
7. What is the difference between voltage amplifier and power amplifier?
8. Sketch ac load line in case of class A power amplifier.
9. Sketch ac load line in case of class B power amplifier.
10. What do you mean by class C power amplifier?
11. Write the principle of class C push-pull amplifier.
12. What are the advantages of class C push-pull amplifier?
13. What are the disadvantages of class C push-pull amplifier?
14. Sketch cross over distortion.
15. Why heat sink is necessary in case of power transistor?
16. Determine the power that 2N1707 can safely dissipate in free air when $T_A=50^{\circ}\text{C}$. Given $T_J=200^{\circ}\text{C}$ and $\theta_{J-A}=100^{\circ}\text{C/w}$.
17. Determine the power that 2N1707 can safely dissipate in free air when $T_A=60^{\circ}\text{C}$. Given $T_J=210^{\circ}\text{C}$ and $\theta_{J-A}=110^{\circ}\text{C/w}$.
18. Determine the power that 2N1707 can safely dissipate in free air when $T_A=55^{\circ}\text{C}$. Given $T_J=190^{\circ}\text{C}$ and $\theta_{J-A}=100^{\circ}\text{C/w}$.

Questions for 3 marks.

1. Determine power dissipation capability of 2N1701 transistor which has been heated with heat sink having $\theta_{HS-A}=\theta_{S-A}=10^{\circ}\text{C/w}$. Given $T_A=50^{\circ}\text{C}$, $T_J=200^{\circ}\text{C}$ and $\theta_{J-c}=7^{\circ}\text{C/w}$ $\theta_{C-A}=93^{\circ}\text{C/w}$.
2. Determine power dissipation capability of 2N1701 transistor which has been heated with heat sink having $\theta_{HS-A}=\theta_{S-A}=12^{\circ}\text{C/w}$. Given $T_A=52^{\circ}\text{C}$, $T_J=210^{\circ}\text{C}$ and $\theta_{J-c}=8^{\circ}\text{C/w}$ $\theta_{C-A}=94^{\circ}\text{C/w}$.
3. Explain in detail difference between voltage amplifier and power amplifier.
4. Write the advantages and disadvantages of power amplifiers.
5. Derive the relation between maximum power and load resistance.
6. A Si power transistor must dissipate 10 watt at a maximum ambient temperature of 45°C . If $T_{jmax}=225^{\circ}\text{C}$, $\theta_{J-C}=12^{\circ}\text{C/w}$ and $\theta_{C-A}=20^{\circ}\text{C/w}$. What is heat sink thermal resistance in Q_{S-A} ?
7. A Si power transistor must dissipate 12 watt at a maximum ambient temperature of 46°C . If $T_{jmax}=220^{\circ}\text{C}$, $\theta_{J-C}=11^{\circ}\text{C/w}$ and $\theta_{C-A}=22^{\circ}\text{C/w}$. What is heat sink thermal resistance in Q_{S-A} ?

8. Sketch and label the diagram of class B push-pull amplifier.

Questions for 4 marks.

1. Explain voltage amplification stage and driver stage in case of power amplifier.
2. Explain voltage amplification stage and output stage in case of power amplifier.
3. Explain driver stage and output stage in case of power amplifier.
4. Explain class A power amplifier and class B power amplifier.
5. Explain class A power amplifier and class C power amplifier.
6. Explain class B power amplifier and class C power amplifier
7. Describe the cross over efficiency of class B push-pull amplifier. How it can be minimized?
8. Draw the composite characteristics curves for two transistors.

Questions for 6 marks.

1. Explain in detail classification of power amplifier.
2. With the neat diagram explain the class B push-pull amplifier.
3. Explain in detail about heat sink.
4. Solve the following example
 - a) Determine power dissipation capability of 2N1701 transistor which has been heated with heat sink having $\theta_{HS-A}=\theta_{S-A}=10^{\circ}\text{C/W}$. Given $T_A=50^{\circ}\text{C}$, $T_J=200^{\circ}\text{C}$ and $\theta_{J-C}=7^{\circ}\text{C/W}$ $\theta_{C-A}=93^{\circ}\text{C/W}$.
 - b) Determine power dissipation capability of 2N1701 transistor which has been heated with heat sink having $\theta_{HS-A}=\theta_{S-A}=12^{\circ}\text{C/W}$. Given $T_A=52^{\circ}\text{C}$, $T_J=210^{\circ}\text{C}$ and $\theta_{J-C}=8^{\circ}\text{C/W}$ $\theta_{C-A}=94^{\circ}\text{C/W}$.
5. Solve the following example
 - a) A power transistor has thermal resistance $Q=300^{\circ}\text{C/W}$ if maximum junction temperature is 900°C . Find the maximum permissible power dissipation.
 - b) If a heat sink is used with the above transistor, the value of Q is reduced to 60°C/W . Find maximum permissible power.

3. FEEDBACK

Questions for 2 marks.

1. What do you mean by feedback.
2. Explain positive feedback.
3. Explain negative feedback.
4. Explain voltage feedback.
5. Explain current feedback.
6. Sketch and label series mixer.
7. Sketch and label shunt mixer.
8. Sketch and label series voltage feedback.
9. Sketch and label series current feedback.
10. Sketch and label shunt voltage feedback.
11. Sketch and label shunt current feedback.
12. Draw the block diagram of feedback.
13. An amplifier has a gain of 2×10^5 without feedback. Determine the gain if negative voltage feedback is applied. Given: $\beta = 0.02$.
14. An amplifier has a gain of 2×10^5 without feedback. Determine the gain if negative voltage feedback is applied. Given: $\beta = 0.04$.
15. An amplifier has a gain of 4×10^5 without feedback. Determine the gain if negative voltage feedback is applied. Given: $\beta = 0.02$.
16. An amplifier has a gain of 3×10^5 without feedback. Determine the gain if negative voltage feedback is applied. Given: $\beta = 0.03$.

Questions for 3 marks.

1. Draw the block diagram of concept of feedback.
2. Draw the block diagram of sampling network.
3. Explain why series voltage feedback connection is mostly used.
4. Explain the effect of negative feedback on gain.
5. Explain the effect of negative feedback on input impedance.
6. Explain the effect of negative feedback on bandwidth.
7. Explain series voltage feedback.
8. Explain series current feedback.
9. Explain shunt voltage feedback.
10. Explain shunt current feedback.
11. Explain how negative feedback in an amplifier helps in reducing the distortion.
12. Explain how negative feedback in an amplifier helps in stabilizing the gain.
13. Explain how negative feedback in an amplifier helps in increasing the input impedance.
14. Explain how negative feedback in an amplifier helps in reducing the output impedance.
15. Explain how negative feedback in an amplifier helps in increasing the bandwidth.
16. When negative voltage feedback is applied to an amplifier of gain 100, the overall gain falls to 50. Calculate the feedback factor.

16. When negative voltage feedback is applied to an amplifier of gain 1000 the overall gain falls to 6. Calculate the feedback factor.

17. When negative voltage feedback is applied to an amplifier of gain 60 the overall gain falls to 50. Calculate the feedback factor.

18. The gain and distortion of an amplifier are 150 and 5 % respectively, without feedback. If the stage has 10 % of its output voltage applied as negative feedback, find the distortion of the amplifier with negative feedback.

19. The gain and distortion of an amplifier are 150 and 10 respectively, without feedback. If the stage has 15% of its output voltage applied as negative feedback, find the distortion of the amplifier with negative feedback.

Questions for 4 marks.

1. Explain the concept of feedback with respect to sampling network.
2. Explain the concept of feedback with respect to feedback network.
3. Explain the concept of feedback with respect to mixer network.
4. State and explain types of feedback.
5. Explain the effect of negative feedback on non-linear distortion.
6. An amplifier has an internal gain A of 300. Its output impedance is $2K\Omega$. Negative feedback with feedback factor 0.02 is introduced in the circuit. Calculate the output impedance of the feedback amplifier.
7. Derive an expression for voltage gain of the amplifier with positive and negative feedback.
8. Distinguish between positive and negative feedback.
9. Explain how sustained oscillations are obtained with the help of positive feedback.
10. An amplifier has an internal gain A of 200. Its output impedance is $1K\Omega$. Negative feedback with feedback factor 0.02 is introduced in the circuit. Calculate the output impedance of the feedback amplifier.
11. An amplifier has an internal gain A of 300. Its output impedance is $1K\Omega$. Negative feedback with feedback factor 0.02 is introduced in the circuit. Calculate the output impedance of the feedback amplifier.
12. An amplifier has an internal gain A of 300. Its output impedance is $1K\Omega$. Negative feedback with feedback factor 0.03 is introduced in the circuit. Calculate the output impedance of the feedback amplifier.

Questions for 6 marks.

1. Explain the concept of feedback with respect to sampling network, feedback network and mixer network.
2. Explain Barkhausen criterion.
3. Explain general theory of feedback.
4. Explain negative feedback with respect to gain and non-linear distortion.
5. Explain negative feedback with respect to gain and input impedance.
6. Explain negative feedback with respect to gain and output impedance.

7. Explain negative feedback with respect to gain and bandwidth.
8. Explain negative feedback with respect to non-linear distortion and input impedance.
9. Explain negative feedback with respect to non-linear distortion and output impedance.
10. Explain negative feedback with respect to non-linear distortion and bandwidth.
11. Explain negative feedback with respect to input impedance and output impedance.
12. Explain negative feedback with respect to input impedance and bandwidth.

4. WAVE SHAPING CIRCUITS

Questions for 2 marks.

1. What do you understand by wave shaping circuits?
2. Which elements are used in linear and non-linear wave shaping circuits?
3. Why there is need of wave shaping circuits?
4. What do you mean by differentiator circuits?
5. What do you mean by integrator circuits?
6. What do you mean by clipping circuits?
7. What do you mean by clamping circuits?
8. What do you mean by positive clipper circuits?
9. What do you mean by negative clipper circuits?
10. What do you mean by positive clamping circuits?
11. What do you mean by negative clamping circuits?
12. Sketch the output waveforms from a differentiating circuit when the input is a saw-tooth wave.
13. Sketch the output waveforms from a differentiating circuit when the input is a square wave.

Questions for 3 marks.

1. Write the application of differentiator.
2. Write the application of integrator.
3. Write the application of clamping circuits?
4. Write in detail about positive clipper.
5. Write in detail about negative clipper.
6. Write in detail about positive clipper.
7. Write in detail about positive clamper.
8. Write in detail about negative clamper.
9. What is the effect of time constant of an RC circuit on differentiated wave?
10. Sketch the output waveform from the differentiating circuit when the input is square wave for $T=0.2RC$.
11. Sketch the output waveform from the differentiating circuit when the input is square wave for $T=RC$.

Questions for 4 marks.

1. Sketch the output waveforms from a differentiating circuit when the input is a saw-tooth wave and a triangular wave.

2. Sketch the output waveforms from a differentiating circuit when the input is a saw-tooth wave and a sine wave.
3. Sketch the output waveforms from a differentiating circuit when the input is a saw-tooth wave a sine wave square a triangular wave
4. Sketch the output waveforms from a differentiating circuit when the input is square wave and saw tooth wave.
5. Show that the output from a differentiating circuit is derivative of the input.
6. Show that the output from an integrating circuit is integral of the input.
7. Write in detail about biased clipper.
8. Write in detail about combination clipper.

Questions for 6 marks.

1. Show that the output from a differentiating circuit is derivative of the input. What assumption is made in the derivation?
2. Sketch the output waveforms from a differentiating circuit when the input is a) a saw-tooth wave b) a sine wave and c) a triangular wave.
3. What is the effect of time constant of an RC circuit on differentiated wave? Sketch the output waveform from the differentiating circuit when the input is square wave for $T=0.2RC$.
4. What is the effect of time constant of an RC circuit on differentiated wave? Sketch the output waveform from the differentiating circuit when the input is square wave for $T=RC$.

5. DIFFERENTIAL AMPLIFIER

Questions for 2 marks.

1. Why differential amplifier is necessary?
2. Define differential amplifier.
3. Draw the neat-labeled diagram for dual input, balanced output.
4. Draw the neat-labeled diagram for dual input, unbalanced output.
5. Draw the neat-labeled diagram for single input, balanced output.
6. Draw the neat-labeled diagram for single input, unbalanced output.
7. Draw the neat-labeled diagram for emitter coupled differential amplifier.
8. Define the term CMRR.
9. CMRR for the differential amplifier should be high. Comment.
10. Define differential gain related to a differential amplifier.
11. Define common mode gain related to a differential amplifier.

Questions for 3 marks.

1. Explain the black box concept.
2. Draw the neat-labeled diagram for dual input, balanced output.
3. Draw the neat-labeled diagram for dual input, unbalanced output.
4. Draw the neat-labeled diagram for single input, balanced output.
5. Draw the neat-labeled diagram for single input, unbalanced output.
6. Explain the necessity of constant source in differential amplifier.
7. Sketch and labeled the diagram of differential amplifier with constant current source.
8. Sketch and labeled the graph of transfer characteristics of differential amplifier.
9. Sketch and labeled the circuit diagram of differential amplifier with constant current source.
10. Define differential gain and common mode gain.
11. Define differential gain and CMRR.

12. Define CMRR and common mode gain.
13. Draw the transfer characteristics of differential amplifier circuits.
14. Draw the circuit diagram differential amplifier using constant current source.

Questions for 4 marks.

1. Define and explain the term CMRR.
2. What are different configurations of differential amplifier? Draw the neat-labeled diagram for dual input, balanced output and dual input, unbalanced output.
3. What are different configurations of differential amplifier? Draw the neat-labeled diagram for single input, balanced output and single input, unbalanced output.
4. Draw the circuit of emitter coupled differential amplifier and explain.
5. Draw the transfer characteristics of a differential and explain its significance.
6. What are different configurations of differential amplifier? Draw the neat-labeled diagram for single input, balanced output and single input, unbalanced output.
7. What are different configurations of differential amplifier? Draw the neat-labeled diagram for dual input, balanced output and single input, balanced output.
8. What are different configurations of differential amplifier? Draw the neat-labeled diagram for dual input, balanced output and single input, unbalanced output.

Questions for 6 marks.

1. A differential amplifier has a differential gain A_d of 100. The input voltages applied are $v_1=1\text{mv}$ and $v_2=0.9\text{mv}$. Calculate the output voltage for a) $\text{CMRR}=100$ b) $\text{CMRR}=1000$ and c) $\text{CMRR}=10,000$.
2. A differential amplifier has a differential gain A_d of 120. The input voltages applied are $v_1=1\text{mv}$ and $v_2=0.9\text{mv}$. Calculate the output voltage for a) $\text{CMRR}=100$ b) $\text{CMRR}=1000$ and c) $\text{CMRR}=10,000$.
3. Define differential amplifier and explain emitter differential amplifier.
4. Define differential amplifier. Draw the transfer characteristics of a differential and explain its significance.
5. Explain the necessity of constant source in differential amplifier. Prove that the circuit works as constant current source.

6. What are different configurations of differential amplifier? Draw the neat-labeled diagram for a) dual input, balanced output, b) dual input, unbalanced output and c) single input, balanced output.

7. What are different configurations of differential amplifier? Draw the neat-labeled diagram for a) dual input, balanced output, b) dual input, unbalanced output and c) single input, unbalanced output.

ELE-222 SEMESTER - II: LINEAR INTEGRATED CIRCUITS & APPLICATIONS.

1. OPERATIONAL AMPLIFIER.

Question for 2 marks

1. Op-amp is popular. Comment
2. What do you mean by inverting input?
3. What do you mean by non-inverting input?
4. Draw the schematic symbol for Op-amp.
5. Explain phase inversion due to inverting input.
6. Explain non-phase inversion due to non-inverting input.
7. Explain open loop voltage gain.
8. Explain input bias current.
9. Explain slew rate.
10. Why an Op-amp is called as operational amplifier?
11. Define input impedance.
12. Define output impedance.
13. Define input bias current.
14. Define offset current.
15. Define offset voltage.
16. Define slew rate.
17. Define open loop gain
18. What is the voltage follower?

Questions for 3 marks

1. Draw the block diagram of operational amplifier.
2. Explain input impedance.
3. Explain output impedance.
4. Explain voltage follower.
5. For the inverting amplifier given that $R_1=1K\Omega$ and $R_f=10K\Omega$. Assuming an ideal amplifier, calculate the output voltage for the input of 1V.

6. For the inverting amplifier given that $R_1=10\text{K}\Omega$ and $R_f=100\text{K}\Omega$. Assuming an ideal amplifier, calculate the output voltage for the input of 10V.
7. For the inverting amplifier given that $R_1=\text{K}\Omega$ and $R_f=10\text{K}\Omega$. Assuming an ideal amplifier, calculate the output voltage for the input of 1V.
8. For the inverting amplifier given that $R_1=5\text{K}\Omega$ and $R_f=50\text{K}\Omega$. Assuming an ideal amplifier, calculate the output voltage for the input of 1V.
9. For the non-inverting amplifier given that input voltage is 3V and $R_1=1\text{K}\Omega$ and $R_f=10\text{K}\Omega$. Calculate the output voltage.
10. For the non-inverting amplifier given that input voltage is 5V and $R_1=1\text{K}\Omega$ and $R_f=5\text{K}\Omega$. Calculate the output voltage.
11. For the non-inverting amplifier given that input voltage is 6V and $R_1=2\text{K}\Omega$ and $R_f=10\text{K}\Omega$. Calculate the output voltage.
12. For the non-inverting amplifier given that input voltage is 4V and $R_1=1\text{K}\Omega$ and $R_f=5\text{K}\Omega$. Calculate the output voltage.

Questions for 4 marks

1. Explain input offset voltage.
2. Explain input offset current.
3. Explain input bias current and slew rate.
4. Explain open loop voltage gain and input bias current.
5. Explain open loop voltage gain and slew rate.
6. Explain why an op-amp is called operational amplifier. What mathematical operations can be performed using op-amp?
7. Draw the circuit symbol of op-amp. Explain what is mean by inverting input?
8. Draw the circuit symbol of op-amp. Explain what is mean by non-inverting input?
9. What is voltage follower? Explain it in detail.

Questions for 6 marks

1. Draw the block diagram of operational amplifier and explain it in detail.
2. Describe the ideal characteristics of Op-amp.
3. Explain concept of virtual ground.
4. Draw the circuit symbol of op-amp. Explain what is mean by inverting input and non-inverting input?
5. List the ideal characteristics of op-amp.

2. GENERAL APPLICATIONS

Questions for 2 marks

1. What do you mean by summing amplifier?
2. Draw the diagram of inverting adder.
3. Draw the diagram of non-inverting adder.
4. Draw the diagram of subtractor.
5. Draw the diagram of integrator.
6. Draw the diagram of differentiator.
7. Draw the diagram of voltage to current converter with floating load.
8. Draw the diagram of voltage to current converter with floating grounded load.
9. Draw the diagram of basic logarithmic amplifier using diode.
10. What is instrumentation amplifier?

Questions for 3 marks

1. Draw the diagram of basic instrumentation amplifier with 3 op-amps.
2. Explain voltage to current converter.
3. Explain inverting adder for 3 inputs.
4. Explain non-inverting adder for 3 inputs.
5. Draw the diagram of integrator and differentiator circuit.
6. Draw the diagram of integrator and adder circuit.
7. Draw the diagram of integrator and subtractor circuit.
8. Draw the diagram of adder and differentiator circuit.
9. Draw the diagram of adder and subtractor circuit.
10. Draw the diagram of subtractor and differentiator circuit.

Questions for 4 marks

1. Explain V to I converter using op-amp floating load.
2. Explain V to I converter using op-amp grounded load.
3. How op-amps can be used to subtract the two input voltage?
4. For the inverting amplifier if the input voltages are 1V, 2V and 3V and corresponding resistances are 1K, 2K and 3K respectively and feed back resistor is 1.5K. Calculate the output voltage.
5. For the inverting amplifier if the input voltages are 2V, 4V and 6V and corresponding resistances are 2K, 4K and 6K respectively and feed back resistor is 3K. Calculate the output voltage.

6. For the inverting amplifier if the input voltages are 3V, 5V and 7V and corresponding resistances are 3K, 5K and 7K respectively and feed back resistor is 5K. Calculate the output voltage.
7. For the subtractor circuit using an op-amp input voltages are $V_1=5V$ and $V_2=2V$ and $R_1=10K$ and $R_2=20k$ respectively. Calculate the output voltage.
8. For the subtractor circuit using an op-amp input voltages are $V_1=7V$ and $V_2=3V$ and $R_1=10K$ and $R_2=20k$ respectively. Calculate the output voltage.
9. For the subtractor circuit using an op-amp input voltages are $V_1=2V$ and $V_2=3V$ and $R_1=10K$ and $R_2=20k$ respectively. Calculate the output voltage.

Questions for 6 marks

1. What is instrumentation amplifier? What are the basic requirements of an instrumentation amplifier?
2. Describe the circuit of instrumentation amplifier using 3 op-amps.
3. Describe the log amplifier using op-amps.
4. Explain voltage to current converter and describe voltage to current converter with floating load.
5. Explain voltage to current converter and describe voltage to current converter with grounded load.

3. ACTIVE FILTERS AND OSCILLATORS

Questions for 2 marks

1. What do you mean by filters?
2. What do you mean by analog and digital filters?
3. What do you mean by passive and active filters?
4. What do you mean by audio and radio frequency filters.
5. Name the most commonly used filters.
6. Draw the frequency response of low pass active filters.
7. Draw the frequency response of high pass active filters.
8. Draw the frequency response of band pass filters.
9. Draw the frequency response of reject filters.
10. Draw the frequency response of phase shift between input and output voltage of an all pass filter.
11. What do you mean by stop band?
12. What do you mean by pass band?
13. What do you mean by oscillator?
14. What is the need of an oscillator?
15. What are the conditions of the sustained oscillations?
16. Draw the circuit diagram for basic triangular square wave generator.

Questions for 3 marks

1. Explain the frequency response of low pass active filters.
2. Explain the frequency response of high pass active filters.
3. Explain the frequency response of band pass filters.
4. Explain the frequency response of reject filters.
5. Explain the frequency response of phase shift between input and output voltage of an all pass filter.
6. Draw the circuit of first order low pass filter and frequency response of it.
7. Draw the circuit of first order high pass filter and frequency response of it.
8. What are the advantages and disadvantages of the phase shift oscillator?
9. Draw the circuit diagram for phase shift oscillator.
10. Write the principle of phase shift oscillator.
11. Draw the circuit diagram for the wein bridge oscillator.
12. Draw the waveforms of square wave generator.

Questions for 4 marks

1. Write the advantages of active filters over the passive filters.

2. Write the limitations of the active filters over the passive filters.
3. Differentiate between the active filters and passive filters.
4. What is filter? Discuss the types of filters.
5. Explain the designing of first order low pass filter.
6. Explain the designing of first order high pass filter.
7. Design the low pass filter for 1 KHz frequency and pass-band gain of 11.
8. Design the low pass filter for 10 KHz frequency and pass-band gain of 15.
9. Mention the advantages of oscillator.
10. With a neat diagram explain the action of phase shift oscillator.

Questions for 6 marks

1. Explain active filters and differentiate between the active filters and passive filters.
2. Explain passive filters and differentiate between the active filters and passive filters.
3. Draw the neat circuit of first order low pass filter and describe it.
4. Draw the neat circuit of first order high pass filter and describe it.
5. With a neat diagram explain the action of phase shift oscillator. Write the advantages of phase shift oscillator.
6. With a neat diagram explain the action of phase shift oscillator. Write the disadvantages of phase shift oscillator.
7. Explain the wein bridge oscillator in detail.
8. With the help of a circuit diagram and associated wave forms describe the working of basic triangular square wave generator using op-amps.

4. COMPARATORS

Questions for 2 marks

1. What do you mean by comparator?
2. Draw the circuit of comparator.
3. Write the applications of the comparator.
4. Draw the circuit diagram of Schmitt trigger.
5. Draw the input wave form of the Schmitt trigger.
6. Draw the output wave form of the Schmitt trigger.
7. Draw the graph of hysteresis voltage.

Questions for 3 marks

1. Draw the wave form of comparator.
2. Draw the circuit diagram for precision half wave rectifier.
3. Draw the circuit diagram for precision full wave rectifier.
4. Draw the wave forms for precision half wave and full wave rectifier.
5. What do you mean by precision rectifier?
6. What do you mean by half wave precision rectifier?
7. What do you mean by full wave precision rectifier?
8. Draw a circuit for a positive peak detector and its wave form for input and output.
9. What do you mean by basic peak detector?

Questions for 4 marks

1. With a neat diagram explain the comparator using an op-amp.
2. In the circuit of Schmitt trigger $R_1=50K$ and $R_2=100\Omega$ and $V_i=1V_{pp}$ (peak to peak) sine wave and saturation voltage = $\pm 14V$. Determine the threshold voltages V_{UT} and V_{LT} .
3. In the circuit of Schmitt trigger $R_1=55K$ and $R_2=110\Omega$ and $V_i=1V_{pp}$ (peak to peak) sine wave and saturation voltage = $\pm 13V$. Determine the threshold voltages V_{UT} and V_{LT} .
4. Design a wein bridge oscillator using op-amp for $f_0 = 965Hz$.
5. Design a wein bridge oscillator using op-amp for $f_0 = 1005Hz$.
6. Draw the neat circuit of half wave precision rectifier and explain its working.
7. Explain the operation of basic peak detector using necessary wave form.

Questions for 6 marks

1. What is comparator? How op-amp can be used as comparator.
2. Differentiate between the comparator and Schmitt trigger.

3. Describe the Schmitt trigger using an op-amp.
4. Draw the neat circuit of full wave precision rectifier and explain its working.
5. What is peak detector? Explain the operation of basic peak detector using necessary wave form.

5. WAVEFORM GENERATORS USING IC-555

Questions for 2 marks

1. List the application of timer.
2. Explain the pin no.1 of the timer.
3. Explain the pin no.2 of the timer.
4. Explain the pin no.3 of the timer.
5. Explain the pin no.4 of the timer.
6. Explain the pin no.5 of the timer.
7. Explain the pin no.6 of the timer.
8. Explain the pin no.7 of the timer.
9. Explain the pin no.8 of the timer.

Questions for 3 marks

1. Draw the functional diagram of IC-555.
2. Draw the pin configuration of IC-555.
3. Explain controlled voltage and threshold of IC-555.
4. Explain controlled voltage and discharge of IC-555.
5. Explain discharge and threshold of IC-555.
6. Explain discharge and output of IC-555.
7. Explain threshold and output of IC-555.
8. Explain controlled voltage and output of IC-555.
9. Explain reset and output of IC-555.
10. Draw the wave forms of the IC-555.
11. Draw the circuit diagram for astable multivibrator as square wave generator.
12. Draw the neat circuit diagram of ramp generator using astable mode.
13. Draw the wave form of ramp generator using astable mode.

Questions for 4 marks

1. Explain the concept of multivibrator.

2. Draw the functional diagram of astable multivibrator.
3. Explain an astable multivibrator using IC-555 with neat diagram.
4. With a neat diagram of astable multivibrator deduce the formula for frequency.
5. What is duty cycle? Obtain an equation of duty cycle for astable operation.
6. Explain with a neat circuit diagram astable multivibrator as square wave generator.
7. Draw the neat diagram of monostable multivibrator using external connection and explain it in detail.
8. Explain the use of IC-555 timer as a frequency divider.
9. Explain the use of IC-555 timer as a pulse stretcher
10. It is possible to produce a square wave using a 555 timer that has exactly 50 % duty cycle? Explain.
11. Determine the frequency of oscillation for the astable multivibrator using IC-555. Given that $R_A=R_B=1K\Omega$ and $C=1000PF$.
12. Determine the frequency of oscillation for the astable multivibrator using IC-555. Given that $R_A=R_B=2K\Omega$ and $C=1000PF$.
13. Calculate the duty cycle for the astable multivibrator using IC-555. Given that $R_A=R_B=2K\Omega$ and $C=1000PF$.
14. Calculate the duty cycle for the astable multivibrator using IC-555. Given that $R_A=R_B=1K\Omega$ and $C=1000PF$.

Questions for 6 marks

1. Explain the pin configuration of IC-555.
2. Give the pin connections of IC-555. Explain the use of each pin.
3. Explain the use of IC-555 as a ramp generator by using astable mode.
4. With a neat diagram, explain bistable multivibrator using IC-555.

PAPEER – II

SEMESTER – I

**ELE – 212: DIGITAL ELECTRONICS &
APPLICATIONS.**

SEMESTER – II

ELE – 221: INSTRUMENTATION.

ELE – 212: DIGITAL ELECTRONICS & APPLICATIONS.

1. K-MAP

Questions for 2 marks

1. What is K-map?
2. “Simplification of logic expressions using K-map is simple than using Boolean laws and theorems” Comment:
3. Construct the K-map for the following truth table.

Inputs			Outputs
A	B	C	Y
0	0	0	0
0	0	1	1
0	1	0	1
0	1	1	0
1	0	0	1
1	0	1	1
1	1	0	0
1	1	1	1

4. Construct the K-map for the following truth table.

Inputs		Outputs
0	0	0
0	1	0
1	0	1
1	1	0

5. Map the following expression on a K-map.

$$A.B.\bar{C} + \bar{A}.B.\bar{C} + \bar{A}.\bar{B}.\bar{C} + A.\bar{B}.\bar{C}$$

6. Map the following expression on a K-map.

$$\bar{A}\bar{B}.C + A.B.C + \bar{A}.B.C + A.\bar{B}.\bar{C}$$

7. Map the following expression on a K-map.

$$A.B + \bar{A}.\bar{B} + A.\bar{B}$$

8. Map the following expression on a K-map.

$$(\bar{A}+\bar{B}+\bar{C})(A+\bar{B}+C)(A+\bar{B}+\bar{C})(A+B+C)$$

9. Map the following expression on a K-map.

$$(A+\bar{B}+C)(\bar{A}+B+\bar{C})(A+B+\bar{C})(\bar{A}+B+C)$$

10. On a K-map, grouping of 0s produces

- a POS expressions
- a SOP expressions
- a “don’t care condition”
- AND – OR logic.

11. An example of standard SOP expression is

- $\bar{A}.B + A.\bar{B}.C + A.B.\bar{D}$
- $A.\bar{B} + \bar{A}.B + \bar{A}.\bar{B}$
- $A.\bar{B}.\bar{C}.D + \bar{A}.B + A$
- $A.\bar{B}.C + A.\bar{C}.D$

12. An example of standard SOP expression is

- $A(B+C) + A.\bar{C}$
- $(\bar{A}+B)(\bar{A}+B+C)$
- $\bar{A}+\bar{B}+B.C$

d) both answers (a) and (b)

13. Draw a 2 variable K-map and show the product terms in each cell.

14. Draw a 3 variable K-map and show the product terms in each cell.

15. Draw a 4 variable K-map and show the product terms in each cell.

16. Construct the K-map for the following truth table.

Inputs			Outputs
A	B	C	Y

0	0	0	1
0	0	1	1
0	1	0	0
0	1	1	0
1	0	0	1
1	0	1	1
1	1	0	0
1	1	1	0

17. Construct the K-map for the following truth table.

Inputs		Outputs
0	0	0
0	1	0
1	0	0
1	1	1

18. Construct the K-map for the three variable truth table in which the output is high for the following input conditions 1101, 1010, 0101, 1111.

19. Construct the K-map for the three variable truth table in which the output is high for the following input conditions 1100, 1000, 0100, 1000.

20. Draw a pair, a quad, and an octet on K-map.

21. Define minterm.

22. Define maxterm.

Questions for 3 marks

1. Draw the K-map for the given expression and make the groupings.

$$A\bar{B}.C + A.B.\bar{C} + A\bar{B}.\bar{C} + \bar{A}\bar{B}.C + \bar{A}.B.C + A.B.C$$

2. Draw the K-map for the given expression and make the groupings.

$$(\bar{A}+\bar{B}+\bar{C})(\bar{A}+B+\bar{C})(\bar{A}+B+C)(A+B+\bar{C})(A+B+C)(A+\bar{B}+\bar{C})$$

3. Draw the K-map for the given expression and make the groupings.

$$\bar{A}\bar{B}.\bar{C}.\bar{D} + \bar{A}\bar{B}.C.D + \bar{A}.B.C.D + \bar{A}\bar{B}.C.\bar{D} + \bar{A}.B.\bar{C}.\bar{D}$$

4. How pair in K-map eliminates one variable and its complement? Explain it with suitable example.

- How quad in K-map eliminates two variables and their compliments? Explain it with suitable example.
- How an octet in K-map eliminates three variables and their compliments? Explain it with suitable example.

Questions for 4 marks

- Design half adder using K-map.
- Design half subtractor using K-map.
- What is don't care condition? Explain it with suitable example.
- Explain the term "Rolling the map".
- Simplify the following SOP equation using the K-map technique.

$$\bar{A}.B + \bar{A}.B.\bar{C} + A.B.\bar{C} + A.\bar{B}.\bar{C}$$

- Simplify the following SOP equation using the K-map technique.

$$\bar{A}.B.C + A.B.C + A.\bar{B}.\bar{C} + \bar{A}.\bar{C}$$

- Use a K-map to find the minimum SOP form for following equation.

$$\bar{A}.B.\bar{C}.D + A.\bar{B}.\bar{C}.D + \bar{A}.\bar{B}.\bar{C}.D + A.B.\bar{C}.D + A.B.\bar{C}.\bar{D} + A.B.C.D$$

- Simplify the given expression by K-mapping.

$$\bar{A}.\bar{B}.\bar{C}.\bar{D} + \bar{A}.\bar{B}.\bar{C}.D + \bar{A}.\bar{B}.C.\bar{D} + \bar{A}.\bar{B}.C.D + \bar{A}.\bar{B}.\bar{C}.\bar{D} + \bar{A}.\bar{B}.\bar{C}.D + \bar{A}.\bar{B}.C.\bar{D} + \bar{A}.\bar{B}.C.D + \bar{A}.\bar{B}.\bar{C}.\bar{D}$$

- Use a K-map to simplify the following expression to a minimum SOP form.

$$A.B.\bar{C}.\bar{D} + \bar{A}.\bar{B}.\bar{C}.\bar{D} + \bar{A}.\bar{B}.C.\bar{D} + A.B.C.\bar{D}$$

- Use a K-map to reduce the following expression to a minimum SOP form.

$$\bar{A}.\bar{B}.\bar{C}.\bar{D} + A.\bar{B}.\bar{C}.\bar{D} + \bar{A}.\bar{B}.C.\bar{D} + A.\bar{B}.C.\bar{D}$$

Questions for 6 marks

- Simplify the following SOP equation using the K-mapping procedure and realise the simplified equation using AND – OR gates..

$$Y = \bar{A}.\bar{B}.\bar{C} + A.\bar{C}.\bar{D} + A.\bar{B} + A.B.C.\bar{D} + \bar{A}.\bar{B}.C$$

- Explain the properties of K-map.

3. Simplify the following SOP equation using the K-mapping procedure and realise the simplified equation using AND – OR gates.

$$Y = \bar{A}\bar{B}\bar{D} + A\bar{C}\bar{D} + \bar{A}B\bar{C} + A.B.\bar{C}.D + A.\bar{B}.C.\bar{D}$$

4. Simplify the following SOP equation using the K-mapping procedure and realise the simplified equation using AND – OR gates.

$$Y = \bar{A}\bar{D} + A.\bar{B}.\bar{D} + \bar{A}.\bar{C}.D + \bar{A}.C.D$$

5. Design full adder using K-map and realise the sum and carry outputs using AND – OR gates.
6. Design full adder using K-map and realise the sum and carry outputs using NAND-NAND gates.
7. Design full subtractor using K-map and realise the difference and borrow outputs using AND –OR gates.
8. Design full subtractor using K-map and realise the difference and borrow outputs using NAND-NAND gates.

2. COUNTER

Questions for 2 marks

1. Define Synchronous counter.
2. Define Asynchronous counter.
3. "Asynchronous counter is faster in operation than asynchronous counter"
comment.
4. Define modulus of counter.
5. Define up-down counter.
6. Draw the block diagram of MOD -3 counter.
7. A 4-bit asynchronous counter uses Flip-Flops propagation delay time 20ns each .The maximum possible time required for change of state is
a) 60 ns b) 20 ns c) 80 ns d) 40 ns
8. A 4-bit synchronous counter uses Flip-Flops propagation delay time 20ns each .The maximum possible time required for change of state is
a) 60 ns b) 20 ns c) 80 ns d) 40 ns
9. Determine the number of flip-flops that would be required to build the following counters:
a) Mod -12 b) Mod-31
10. Determine the number of flip-flops that would be required to build the following counters:
a) Mod -19 b) Mod-6
11. Determine the number of flip-flops that would be required to build the following counters:
a) Mod -15 b) Mod-34
12. Determine the number of flip-flops that would be required to build the following counters:
a) Mod -17 b) Mod-11
13. Determine the number of possible states in a counter composed of the following

4. Draw the block diagram of decade counter & explain its operation.
5. Draw the block diagram of shift counter & explain its operation.
6. Calculate the frequency of 4-bit ripple counter, if the period of waveform at the last flip-flop is 64 microsecond.
7. Draw the block diagram of 4-bit asynchronous counter & timing diagram.
8. Draw the block diagram of 4-bit synchronous counter and timing diagram.

Questions for 6 marks

1. Draw the block diagram of 3-bit up-down counter & explain its operation with truth table.
2. Explain 4 – bit asynchronous counter with block diagram, truth table & timing diagram.
3. Explain 4 – bit synchronous counter with block diagram, truth table & timing diagram.

3. DATA CONVERTERS

Questions for 2 marks

1. Why is it difficult to build an accurate 8 – bit binary weighted DAC?
2. What is the fastest method of A/D conversion?
3. What is the advantage of R/2R ladder DACs over those that use binary- weighted register?
4. The equivalent weighted of the LSB in a 4 – bit variable.
5. What is the percent resolution of a 4 – bit DAC?
6. What is the percent resolution of a 3-bit DAC?
7. Define the term accuracy of DACs.
8. Find the accuracy of 4-bit DAC if the true value of a voltage level is 12V. and its measured value using instrument is 11.9V.
9. Find the accuracy of 12 - bit DAC. Assume an amplitude level of 10V.
10. Find the accuracy of 10 - bit DAC. Assume an amplitude level of 10V.
11. Draw the circuit diagram of R-2R DAC.
12. Determine the output voltage of R-2R DAC due to MSB.
13. Determine the output voltage of R-2R DAC due to the second MSB.
14. Find the resolution of a 4 stage ADC.

Questions for 3 marks

1. Draw the circuit diagram of R-2R DAC and state its advantages.
2. Draw the circuit diagram of binary weighted resistor DAC.
What is its drawback?
3. Draw the diagram of simultaneous ADC.
4. Draw the diagram of successive approximation ADC.
State its advantages.
5. Draw the diagram of successive approximation ADC.
State its disadvantages

6. What is ADC? State the advantages of simultaneous ADC.
7. What is ADC? State the disadvantages of simultaneous ADC.
8. Draw the diagram of counter type ADC.
9. What is ADC? State the advantages of counter type ADC.
10. What is ADC? State the disadvantages of counter type ADC.

Questions for 4 marks

1. Explain the operation of binary weighted resistor DAC.
2. Explain the operation of R-2R DAC.
3. State the advantages & disadvantages of simultaneous ADC.
4. State the advantages & disadvantages of counter type ADC.
5. State the advantages & disadvantages of successive approximation ADC.
6. Find a output voltage of a 6-bit binary ladder with following inputs,
 $0 = 0V$. and $1 = +10V$
a) 101001 b) 1110111
7. What are output voltage due to each bit in a 5 - bit ladders, if $0 = 0V$ and $1 = +10V$.
8. Find a output voltage of a 4-bit binary ladder with following inputs,
 $0 = 0V$. and $1 = +8V$.
a) 1001 b) 1100
9. What are output voltage due to each bit in a 4 – bit ladders,
if $0 = 0V$ and $1 = +8V$.

Questions for 6 marks

1. Explain the operation of counter type ADC. Discuss it merits and demerits.
2. Explain the operation of Simultaneous ADC. Discuss its merits and demerits.
3. Explain the operation of successive approximation ADC. Discuss it merits and demerits.

4. DIGITAL FREQUENCY METER

Questions for 2 marks

1. Draw the basic block diagram of DFM.
2. Explain the principle of working of DFM.
3. Draw the block diagram of time base generator of DFM.
4. State the function of Schmitt trigger in DFM.
5. State the function of crystal oscillator in DFM. Why the other type of sinusoidal oscillator is not used in DFM?

Questions for 3 marks

1. Explain time base generator in DFM.

Questions for 4 marks

1. Draw the block diagram of DFM and explain it.
2. Explain with help of block diagram period measurement mode in DFM.
3. Explain with the help of block diagram frequency measurement in DFM.

ELE – 222: INSTRUMENTATION

1. TRANSDUCERS

Questions for 2 marks

1. The strain gauge is transducer.
 - a) Active b) Passive c) Hybrid b) None of the above
2. A high gauge factor means relatively high change.....
 - a) Length 2) Capacitance 3) Resistance 4) Inductance
4. Define a transducer. Give their classification.
5. Define Active transducer.
6. Define Passive transducer.
7. Give names of transducer used for measurement of each physical quantity.
 - i) Displacement ii) pressure or force
8. Name any three transducers. What physical quantity of each gets converted into electrical quantity?
9. Which physical parameters can be measured by Resistance pressure transducer?
10. Which physical parameters can be measured by Strain gauge transducer?
11. Define 'Gauge Factor' for strain gauge transducer.
12. State working principle of resistive transducer.
13. State working principle of strain gauge transducer.

Questions for 3 marks

1. What is passive transducer?
2. What is Active transducer?
3. Define transducer. List any four parameters of transducer.
4. What is LVDT? Where it is used?
5. Explain the operating principle of LVDT.
6. State any three requirements of a good transducer.
7. State the working principle of resistive pressure transducer.
8. State the working principle of strain gauge transducer.

9. State the advantages of LVDT.

Questions for 4 marks

1. What is transducer? State the difference between active & passive transducer.
2. Differentiate between active & passive transducer.
3. Explain any four parameters of transducer.
4. Give any four advantages of Electrical transducer.
5. What are the requirements of a good transducer?
6. How can LVDT be used as displacement of transducer?
7. Explain with neat diagram, resistive pressure transducer.
8. Explain with neat diagram, semiconductor strain gauge transducer.
9. State any four advantages of strain gauge transducer.

Questions for 6 marks

1. Explain active & passive transducer along with suitable examples of each.
2. Explain LVDT as displacement transducer.
3. Describe LVDT transducer in detail.
4. What is LVDT? Explain in detail the working principle of LVDT.
5. What is a transducer? Differentiate between active & passive type transducer.
What are the requirements of a good transducer?
6. Give the advantages of Electrical transducer.
7. Discuss the requirements that are to be considered while selecting a transducer.
8. Discuss the requirements of a good transducer.
9. What is strain gauge? Define gauge factor. Explain semiconductor strain gauge as a displacement transducer.
10. State the basic principle of working of resistive transducer. Explain with neat diagram, resistive pressure transducer.
11. State the basic principle of working of resistive transducer. Explain with neat diagram, semiconductor strain gauge transducer.
12. State advantages & disadvantages of strain gauge transducer.

2. POWER SUPPLY

Questions for 2 marks

1. Define: Line Regulation
2. Define: Load Regulation
3. Draw the block diagram of unregulated power supply.
4. Draw the block diagram of regulated power supply.
5. What is the function of voltage regulator?
6. Which of the following is not an essential element of d.c. power supply.
a) Rectifier b) Filter c) Voltage Regulator d) Voltage Amplifier
7. A voltage regulator is a circuit which
a) Converts the dc voltage into ac voltage.
b) Smoothens the ac variations in dc output voltage.
c) Maintains a constant dc output voltage in spite of the fluctuations in ac input voltage or load current.
d) None of the above.
8. The % load regulation of a power supply providing 100V unloaded & 95V at full load is
a) 5.3% b) 5.0% c) 0.53% d) None of the above
9. Which of the following voltage regulator is preferred for providing large value of load current?
a) Zener diode shunt regulator
b) Transistor series voltage regulator
c) Transistor shunt voltage regulator
d) None of the above
10. The main function of a voltage regulator is to provide a nearly..... output voltage.
a) Sinusoidal b) constant c) smooth d) fluctuating
11. A transistor series voltage regulator is called emitter follower regulator because the emitter of the pass transistor follows thevoltage.
a) Output b) input c) base d) collector

12. Voltage regulator normally use.....
 - a) Positive feedback
 - b) negative feedback
 - c) no feedback
 - d) phase limiting
13. If the output of voltage regulator varies from 20 to 19.8V when the line voltage varies over its specified range, the line regulation is
 - a) 0
 - b) 1%
 - c) 2%
 - d) 5%
14. If the output of voltage regulator varies from 15 to 14.7V between the minimum & maximum load current, the load regulation is
 - a) 0
 - b) 1%
 - c) 2%
 - d) 5%
15. Compared to the ripple into a voltage regulator, the ripple out of a voltage regulator is
 - a) Equal in value
 - b) Much larger
 - c) Much smaller
 - d) impossible to determine.
16. Thermal shutdown occurs in an IC regulator if
 - a) Power dissipation is too low
 - b) Internal temperature is too high
 - c) Current through the device is too low
 - d) Any of the above occurs
17. A 78XX series of voltage regulator produces an output voltage that is
 - a) Positive
 - b) Negative
 - c) Unregulated
 - d) Either positive or negative
18. A shunt regulator is inefficient because
 - a) It wastes power
 - b) It uses series resistor & shunt transistor
 - c) The ratio of output to input power is low
 - d) All of the above
19. A series regulator is more efficient than a shunt regulator because
 - a) It has series resistor
 - b) It can boost the voltage
 - c) The pass transistor replaces the series resistor
 - d) It switches the pass transistor on & off

Questions for 3 marks

1. A power supply has voltage regulation of 2%. If no load voltage is 30V, what is the full load voltage?
2. Explain the need of regulated power supply.
3. State advantages of regulated power supply over unregulated power supply.

4. What is voltage regulator? List the main components of voltage regulator.
5. Compare series & shunt voltage regulators.
6. State functions of following elements of voltage regulator.
 - i) Reference Element
 - ii) Sampling Element
7. State functions of following elements of voltage regulator.
 - i) Error Amplifier
 - ii) Control Element

Questions for 4 marks

1. Explain with a neat diagram, shunt voltage regulator.
2. Explain with a neat diagram, series voltage regulator.
3. Distinguish between unregulated & regulated power supply.
4. Draw the block diagram of regulated power supply, explain each block in short.
5. Explain in brief-Load & Line regulation.
6. Write a short note on – Three terminal voltage regulator
7. List basic elements of a power supply. Distinguish between regulated & unregulated power supplies.
8. Calculate percentage load regulation for a voltage regulator giving 10.2V & 10V outputs at no load & full load conditions respectively

Questions for 6 marks

1. Explain with the help of a block diagram three terminal IC voltage regulator.
2. Draw the functional block diagram of three terminal voltage regulator & explain in brief.
3. Explain with neat circuit diagram dual power supply using IC7815 and IC7915.
4. Define line regulation & load regulation. Elaborate the difference between series & shunt type voltage regulation.
5. Explain the working of shunt regulator. What are its advantages over a series voltage regulator?

3. BASIC ANALOG METERS

Questions for 2 marks

1. State the functions of control spring in PMMC movement.
2. PMMC is basically a meter.
 - a) dc current b) ac current c) dc voltage d) ac voltage
3. A PMMC movement of full-scale deflection current 1mA has a sensitivity of ..
 - a) 1 Ω/V b) 10000 Ω/V c) 10 Ω/V d) 1000 Ω/V
4. A moving coil instrument has resistance of 0.5 Ω & a full-scale deflection of 0.1 A. To convert it into an ammeter of 0-10 A, the shunt resistance should be...
 - a) 0.004 Ω b) 0.005 Ω c) 0.050 Ω d) 0.1 Ω
5. A moving coil instrument has resistance of 100 Ω & a full-scale deflection of 1A. To convert it into a voltmeter of 0-0.5V range, the multiplier resistance should be.....
 - a) 490 Ω b) 600 Ω c) 4900 Ω d) none of these
6. A d'Arsonval movement can be converted into dc ammeter by connecting a resistor inwith it.
7. A d'Arsonval movement can be converted into dc voltmeter by connecting a resistor inwith it.

Questions for 3 marks

1. What is multimeter? Mention its types.

Questions for 4 marks

1. How will you convert the PMMC into dc voltmeter? Explain
2. How will you convert the PMMC into dc ammeter? Explain
3. What is Ayrton shunt? What are its advantages? Draw the circuit for multi range ammeter using it.

4. Draw & label equivalent circuit of practical ammeter & voltmeter. State necessary formulae.
5. Define sensitivity of voltmeter. Illustrate with suitable example loading effect of voltmeter.
6. Explain the use of shunt resistor across PMMC movement in a dc ammeter.
7. Define sensitivity of a voltmeter. State its unit. What do you mean by loading effect of voltmeter?
8. Draw & label equivalent circuit of practical ammeter and voltmeter. State the necessary formulae.
9. Show the circuit arrangement of a series type ohmmeter. What is the reason that zero mark is on right & infinity mark on the left of the scale in this type of ohmmeter.
10. Explain the constructional details & working of PMMC movement.
11. What is multimeter? Give their types. State its uses.
12. Explain multirange voltmeter with the help of circuit diagram.
13. Explain how PMMC movement is converted into dc ammeter.
14. Draw circuit diagram of multirange ammeter using Ayrton shunt. State its advantages.
15. A PMMC movement has $I_g = 0.5\text{mA}$ & $R_g = 1\text{K}\Omega$. Calculate resistance values to convert it into multirange voltmeter having ranges 10V & 50V.
16. Design an ammeter of 0.5 A range using d'Arsonval movement having $I_{fsd} = 100\mu\text{A}$ & $R_m = 500\Omega$.
17. Design dc voltmeter for 0-10V range using PMMC having $I_{fsd} = 1\text{mA}$ & $R_m = 50\Omega$
18. A 1 mA movement with an internal resistance of 100Ω is to be converted into 0 to 100 mA. Calculate the value of shunt resistor.

Questions for 6 marks

1. With the help of a circuit diagram, explain the series type ohmmeter.
2. With a labeled circuit diagram, explain the working of series voltage regulator. Explain also how output current is limited to a desired value.
3. Explain the loading effect with suitable example.

4. Draw a neat diagram of series type ohmmeter & explain how it is calibrated.
5. Define sensitivity of a voltmeter. Illustrate with a suitable example, loading effect of a voltmeter.
6. With the help of neat diagram, explain construction & working of series type ohmmeter.
7. What are the advantages & disadvantages of using shunt? Draw a multirange ammeter using Ayrton shunt.
8. Explain multirange voltmeter with neat circuit diagram. How it can be improved to obtain standard multiplier resistors.
9. Convert a PMMC with $I_g = 1 \text{ mA}$ & $R_g = 100 \Omega$ into multi range voltmeter having ranges 0-10V, 0-50V, 0-250V, 0-500V
10. Draw a circuit diagram of multirange ammeter. A PMMC movement having $I_g = 1 \text{ mA}$ & $R_g = 500 \Omega$ is to be converted into multirange ammeter. Calculate shunt resistances for current ranges 10mA, 50mA & 100mA.
11. A 1mA meter movement with an internal resistance of 100Ω is to be converted into a 0-100mA ammeter. Calculate the value of shunt resistance required.
12. A basic d'Arsonval movement with internal resistance of $1 \text{ K}\Omega$ is to be converted into a multirange voltmeter with voltage ranges of 0-10V, 0-50V, 0-250V & 0-500V. Calculate multiplier resistor values if desired voltmeter sensitivity is $1 \text{ K}\Omega/\text{volt}$
13. Convert a basic d'Arsonval movement with an internal resistance of 50Ω and a full scale deflection current of 2mA into a multirange dc voltmeter with voltage ranges of 0-10V, 0-50V, 0-100V, & 0-250V.
14. A dc voltmeter is rated with sensitivity of $1000 \Omega/\text{volt}$ & is used on its 0-50V range to measure the voltage across $50 \text{ K}\Omega$ resistor in fig (a). Determine error in meter reading.

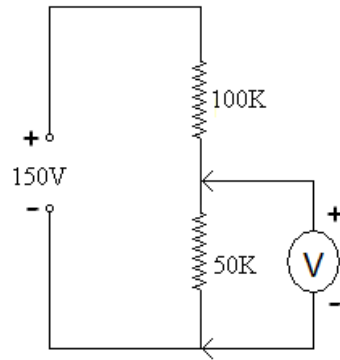

Fig (a)

15. A voltmeter has a sensitivity of $100\Omega/\text{volt}$. It is in the circuit shown in fig (b). The meter reads 4.65V. Calculate the value of R_x on its 50V range.

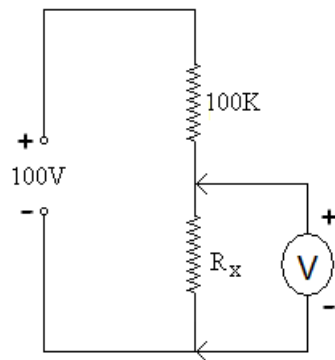

Fig (b)

4. CATHOD RAY OSCILLOSCOPE

Questions for 2 marks

1. Draw labeled block diagram of horizontal deflection system in CRO.
2. Mention any four major components of CRT.
3. State the condition for synchronization of sweep signal with vertical input signal.
4. List any four CRO front panel controls.
5. Which two CRO controls can be used together to obtain sharp & fine display pattern.
6. Time base signal in CRO deflects the electron beam indirection
 - a) Vertical b) Horizontal c) Random d) None of the above
7. The gain & bandwidth response characteristics of CRO are mainly determined by
 - a) Vertical amplifier b) Horizontal amplifier
 - c) Time base generator d) Delay line
8. The condition for synchronization of time base signal with vertical input signal is.....
 - a) $f_v = n f_s$ b) $f_v \neq n f_s$ c) $f_v > n f_s$ d) $f_v < n f_s$
9. The voltage across vertical deflection plates moves electron beam alongdirection.
 - a) Vertical b) Horizontal c) Random d) None of the above
10. The voltage across horizontal deflection plates moves electron beam alongdirection.
 - a) Vertical b) Horizontal c) Random d) None of the above

Questions for 3 marks

1. List the various blocks in horizontal deflection system of CRO.
2. What is synchronization? State the condition for synchronization.
3. What are the uses of CRO?
4. State the basic working principle of CRO.

5. State the function of a) Time base b) Horizontal amplifier c) Trigger circuit
6. State the function of a) Vertical amplifier b) Delay line c) CRT

Questions for 4 marks

1. With a neat circuit diagram, explain the working of time-base generator of CRO.
2. Explain any four front panel controls of CRO.
3. Explain the various types of coupling used in CRO.
4. Explain the function of delay line block in CRO.
5. State the function of following front panel controls of CRO.
Focus, Intensity, Level, Time/Div.
6. Explain the various modes of trigger used in CRO.
7. When the time base control is at 2 ms/div & there are four waves in eight divisions. Find the period & frequency of oscillation.
8. Explain the use of following control knobs in CRO.
i) TRIGGER LEVEL ii) SLOPE
9. Explain following front panel control of CRO
i) INTENSITY ii) FOCUS
10. Explain the modes of trigger used in CRO.
11. With the help of suitable diagram explain the types of coupling used in CRO.
12. Explain the function of SYNC selector used in CRO.
13. Describe the working of vertical amplifier in CRO.
14. Explain synchronization of sweep in CRO.
15. Explain vertical deflection system of CRO.
16. Explain the function of CRO probe.
17. With the help of circuit diagram explain working of triggered sweep generator.

Questions for 6 marks

1. Draw the labeled block diagram of CRO. Explain the function of delay line block.
2. Draw the labeled block diagram of CRO. Explain the function of vertical amplifier.
3. Draw the block diagram of general purpose CRO & label it. State the function of each block.

4. With a neat circuit diagram, explain the working of various CRT controls of CRO.
5. Draw the block diagram of vertical deflection system of CRO and explain the function of INPUT-SELECTOR.
6. Explain in short INTENSITY, FOCUS and TRIGGER LEVEL controls of CRO.
7. With a neat circuit diagram, explain the working of following CRO front panel controls.
 - i) Intensity
 - ii) Focus
 - iii) Astigmatism
 - iv) Vertical & Horizontal Position
8. Explain various modes of trigger in CRO. What is the use of trigger level control on CRO front panel?
9. Draw a circuit connection for CRT and describe the control knobs associated with it.
10. Draw the block diagram of CRO & explain the function of CRO probe.

5. DIGITAL MULTIMETER

Questions for 2 marks

1. Draw the labeled block diagram of DMM.
2. Give the highest & lowest voltages that can be measured a 3 ½ digit DMM.
3. How ac voltage measured with DMM?
4. A DMM basically measures a
 - a) Current
 - b) Voltage
 - c) Resistance
 - d) Capacitance
5. The heart of DMM is
 - a) ADC
 - b) DAC
 - c) d'Arsonval Movement
 - d) Amplifier

Questions for 3 marks

1. Draw a labeled block diagram of DMM.
2. State the working principle of DMM.
3. State any three disadvantages of analog multimeter.
4. State any three advantages of digital multimeter over analog multimeter.

Questions for 4 marks

1. Explain current to voltage conversion in DMM. Draw necessary circuit diagram
2. A DMM has 4 ½ digit display. What is maximum number it can read? What is its resolution?
3. With the help of circuit diagram, explain the working of resistance to voltage converter in DMM.
4. Write a note on auto zeroing.
5. Discuss auto zeroing mechanism in DMM.
6. State the necessity of current to voltage & resistance to voltage conversion in DMM.
7. State any four advantages of digital multimeter over analog multimeter.

8. Explain why digital multimeter is preferred over analog multimeter.

Questions for 6 marks

1. Draw a circuit diagram for auto zeroing in DMM. Explain it.
2. With the help of block diagram, explain the working of DMM.
3. Draw the block diagram of DMM. Explain it.
4. Draw the block diagram of DMM & explain the function of each block.
5. Explain in detail auto zeroing mechanism in DMM.
6. State the necessity of current to voltage & resistance to voltage conversion in DMM. Use a suitable circuit configuration to explain resistance to voltage conversion.
